

One Channel H-Bridge Power Driver AM1106

● Features and Benefits

- Wide supply voltage range up to 11V
- Maximum continuous current output up to 1.3A
- Low $R_{DS(ON)}$ for high efficient H-bridge output.
- Built-in LDO Regulator 5V
- LDO output driver current 100mA
- SOP-8 package for small size PCB layout
- Over current protection
- Over temperature protection
- Low standby current
- Low quiescent current

● Application

- Robotics (R/C servo, Sweeping robot)
- Small Appliances (Reduce PCB surface area and perimeter)
- Any relevant DC motor applications.

● Description

The AM1106 is a channel H-Bridge driver with a built in Low Dropout Regulator (LDO). It provides integrated motor-driver solution for high current power motion control applications. The output driver block consists of N-channel and P-channel power MOSFETs configured as H-Bridge to driver DC motor.

The AM1106 maximum operational voltage is 11V. It can supply up to 1.3A of output continuous current and 2.5A of output peak current. There are internal shutdown function for over-temperature protection and over-current protection ($I_{OCP} = 2.5 A$).

Package material is Pb-Free Product & RoHS compliant for the purpose of environmental protection and for sustainable development of the Earth.

● Ordering Information

Orderable Part Number	Package	Marking
AM1106	SOP-8	AM1106

● **Absolute Maximum Ratings (T_A=25°C)**

Parameter	Symbol	Limits	Unit
Power Supply voltage	PVCC/VCC	12	V
Output continuous current	I _{ocont}	1.3 (NOTE*)	A
Output peak current	I _{omax}	2.5	A
Operate temperature range	T _{opr}	-20~+85	°C
Storage temperature range	T _{stg}	-40~+150	°C

Note *: Based on 40mm² FR4 PCB (1 oz.) at single side PCB.

● **Recommended operating conditions (T_A =25°C)**

(Set the power supply voltage taking allowable dissipation into considering)

Parameter	Symbol	Min	Typ	Max	Unit
Power Supply voltage for H-Bridge	PVCC	2.0(Note**)		11	V
IC operating voltage	VCC	2.0(Note**)		11	V
Signal input IN_A and IN_B voltage	V _{IN_x}	-0.3		V _{cc} +0.3	V
H-bridge output continuous current	I _{OUT}	0		1.3(Note*)	A
Externally applied PWM frequency	F _{IN_x}	0.02		65	KHz

Note* : Based on 40mm² FR4 PCB (1 oz.) at single side PCB.

Note**: The VCC/PVCC should be considered when using 5V LDO.

● Electrical Characteristics (Unless otherwise specified, $T_A = 25^\circ\text{C}$, $V_{PCC}=V_{CC}=6\text{V}$)

Parameter	Symbol	Limit			Unit	Conditions
		Min	Typ	Max		
Power Supplies						
Supply current	I_{CC}		35		μA	Input signal IN_A/B= L/H or H/L, No load on OUT_A/B, no load on LDO
Standby current	I_{STB}			20	μA	Input signal IN_A/B= L, No load on OUT_A/B, no load on LDO
IN_x Inputs						
Input H level voltage	V_{IN_xH}	2.0		V_{CC}	V	
Input L level voltage	V_{IN_xL}	0		0.7	V	
Input pull down resistance	R_{IN_X}		100		$\text{K}\Omega$	
Input frequency	F_{IN_x}	0.02		65	KHz	
H-bridge FETs						
On-resistance	$R_{ds(on)}$		0.58		Ω	$I_O = 0.6\text{A}$ Upper and Lower total
LDO parameter						
LDO output voltage	V_{LDO}	4.6	5	5.4	V	$I_{LDO} = 100\text{mA}$
Line regulation	$\Delta V_{LDO-Line}$			50	mV	$I_{LDO}=100\text{mA}, V_{CC}=5.7 \sim 11\text{V}$
Load regulation	$\Delta V_{LDO-Load}$			50	mV	$I_{LDO} = 0\sim 100\text{mA}$
Dropout voltage	ΔV_{Drop}			300	mV	$I_{LDO}=100\text{mA}$
Power supply rejection ratio	PSRR		45		dB	$I_{LDO}=10\text{mA}, f=120\text{Hz}$ $V_{ripple} = 1\text{Vp-p}$
TSD Protections						
Thermal shutdown protection	TSD_p		130		$^\circ\text{C}$	
Thermal shutdown release	TSD_r		100		$^\circ\text{C}$	

● Block Diagram

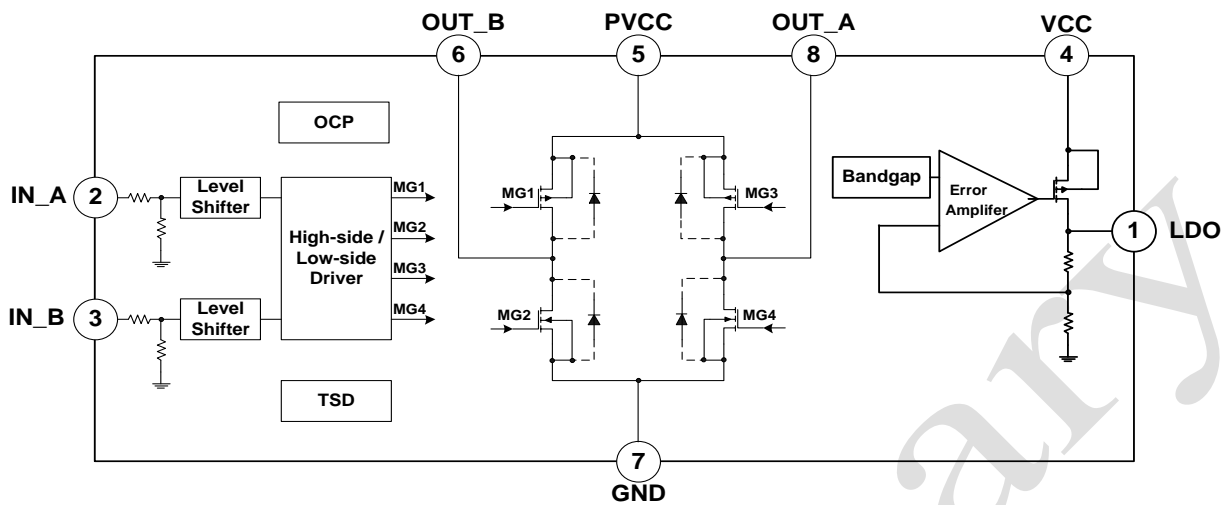

● Input Logic Descriptions

Function truth table

IN_A	IN_B	OUT_A	OUT_B	Mode
L	L	Hi-Z	Hi-Z	Stop
L	H	L	H	Reverse
H	L	H	L	Forward
H	H	L	L	Brake

● Pin configuration SOP-8

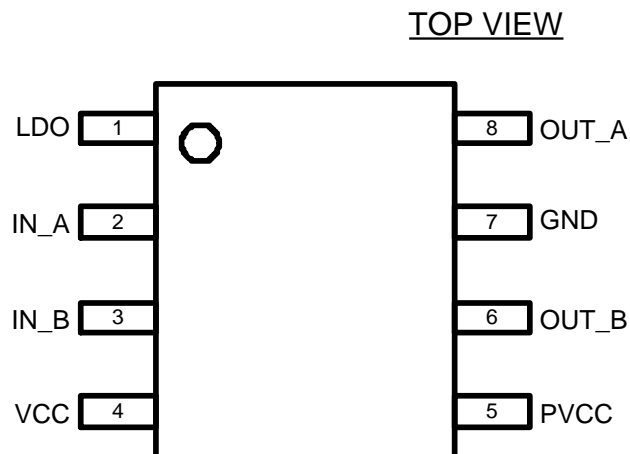

● Pin Descriptions

PIN No.	Pin Name	I/O	Description
1	LDO	O	Low Dropout Regulator
2	IN_A	I	Input Half Bridge A
3	IN_B	I	Input Half Bridge B
4	VCC	-	Power Supply
5	PVCC	-	Power Supply for H-Bridge
6	OUT_B	O	Output Half Bridge B
7	GND	-	Ground Pin
8	OUT_A	O	Output Half Bridge A

● Application

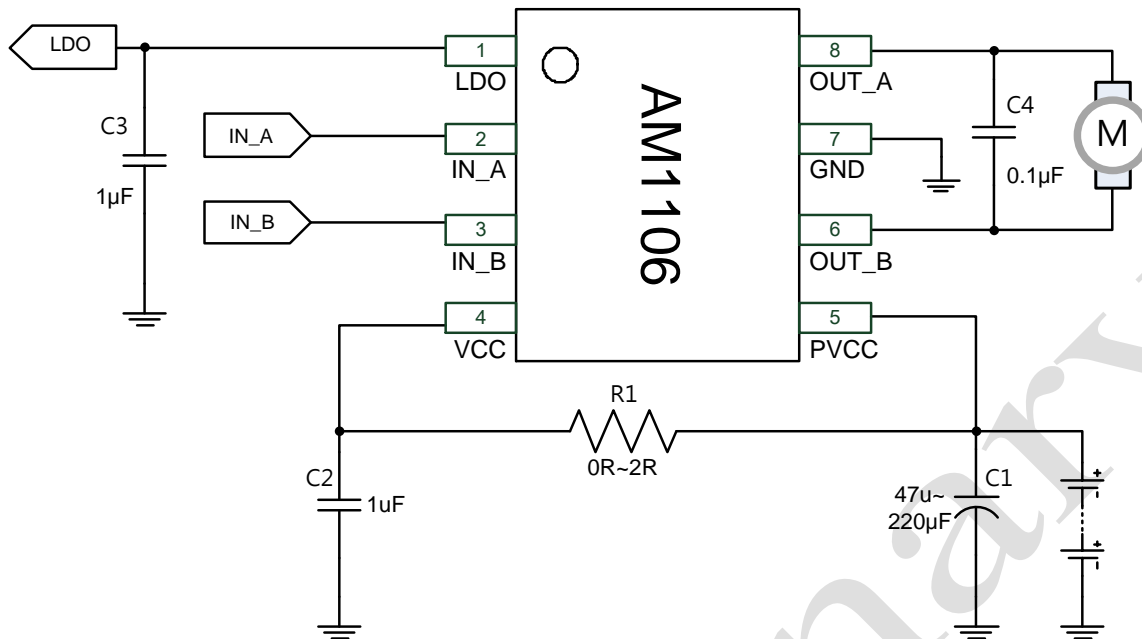

● Circuit Descriptions

The function descriptions of capacitors on the application circuit:

C1 - C2: Power supply PVCC/VCC pin capacitor:

- 1) The capacitor can reduce the power spike when the motor is in motion. To avoid the IC directly damaged by the PVCC/VCC peak voltage. It also can stabilize the power supply voltage and reduce its ripples.
- 2) The C1 capacitor can compensate power when motor starts running.
- 3) The capacitor value (μF) determines the stability of the PVCC/VCC during motor in motion. In general, $47\mu\text{F}$ capacitor is enough in low voltage power (PVCC), $1\mu\text{F}$ capacitor is enough in low voltage power (VCC). If the large voltage power or a heavy loading motor is used, then a larger capacitor would be needed.
- 4) On the PCB configuration, the C1 - C2 must be mounted as close as possible to VCC/PVCC pin (PIN4/PIN5).

C3: The LDO output capacitor

- 1) The capacitor can reduce the power spike while motor is in motion; it also can stabilize the LDO output voltage and reduce its ripples.

C4: The across-output capacitor

- 1) The capacitors can reduce the power spike of motor when operating. Therefore, a $0.1\mu\text{F}$ capacitor is recommended.
- 2) On the PCB configuration, the C4 must be mounted as close as possible to OUT_A&B (PIN 6 & PIN 8).
- 3) The C4 capacitor must be added to the general application.

● Operating Mode Descriptions

H-Bridge basic operating mode :

- a) Forward mode
Definition : When $IN_A=H$, $IN_B=L$, then $OUT_A=H$, $OUT_B=L$
- b) Reverse mode
Definition : When $IN_A=L$, $IN_B=H$, then $OUT_B=H$, $OUT_A=L$
- c) Brake mode
Definition : When $IN_A=IN_B=H$, then $OUT_A=OUT_B=L$
- d) Stop mode
Definition : When $IN_A=IN_B=L$, then $OUT_A=OUT_B=Hi-Z$

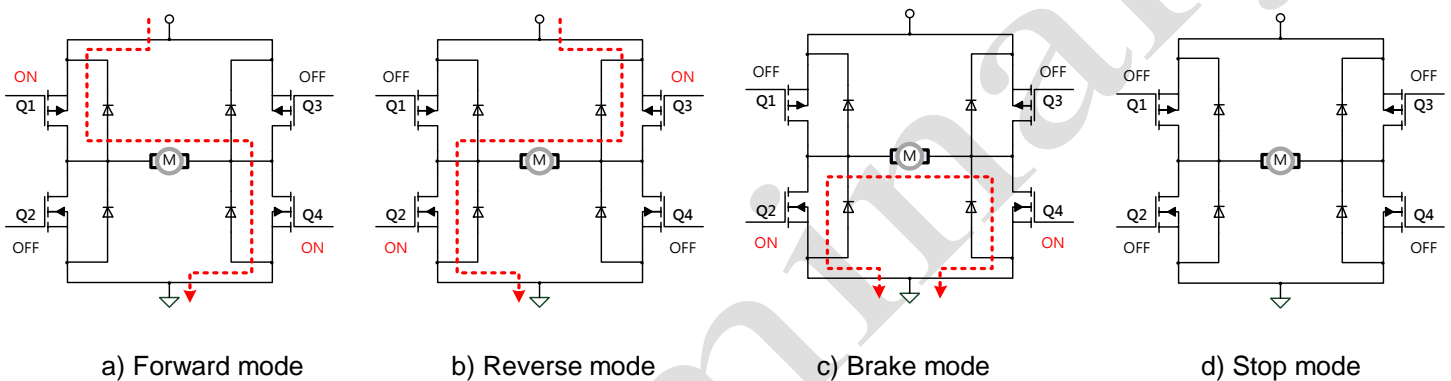

● Protection Mechanisms Descriptions

- 1) Over-current protection (OCP)
While the IC conducts a large current, 2.5A (Typ), the internal over-current protection function will be triggered. The device enter protection mode of auto-recover to avoid damaging IC and system.
- 2) Over-temperature protection
If the IC junction temperature exceeds 130° C (Typ.), the internal over-temperature protection function will be triggered, all FETs in the H-bridge are disabled, that will ensure the safety of customers' products. If the IC junction temperature falls to 100° C(Typ.), the IC resumes automatically.

● Packaging outline --- SOP-8

Unit : mm

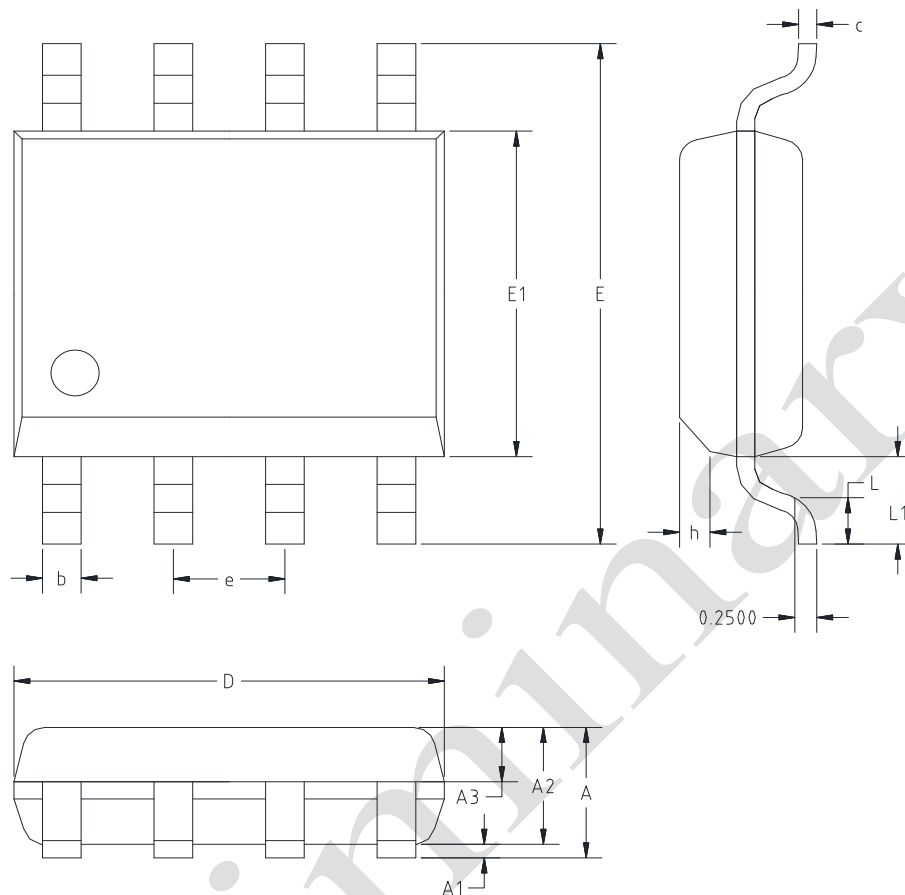

SYMBOL	MILLIMETERS		INCHES	
	Min.	Max.	Min.	Max.
A	--	1.75	--	0.069
A1	0.10	0.225	0.004	0.009
A2	1.30	1.50	0.051	0.059
A3	0.60	0.70	0.024	0.028
b	0.39	0.48	0.015	0.019
c	0.21	0.26	0.008	0.010
D	4.70	5.10	0.185	0.201
E	5.80	6.20	0.228	0.244
E1	3.70	4.10	0.146	0.161
e	1.27 TYP.		0.05 TYP.	
h	0.25	0.50	0.010	0.020
L	0.50	0.80	0.020	0.031
L1	1.05 TYP		0.041 TYP.	

● **Marking Identification**

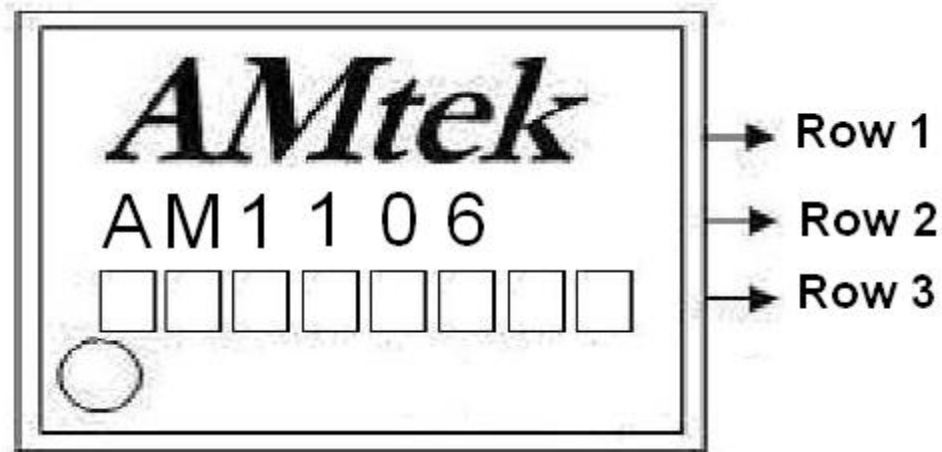

NOTE:

- Row1 : Logo
- Row2 : Device Name
- Row3 : Wafer Lot No, Assembly Year, Assembly Date Code

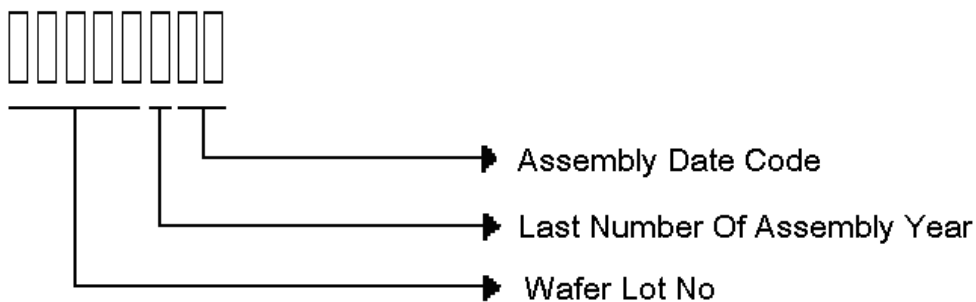

Example: Wafer Lot No is EN520 + Year 2015 is F + Week 40 is 40 , then mark "EN520F40"

The last code of assembly year, explanation as below: :

(Year : A=0,B=1,C=2,D=3,E=4,F=5,G=6,H=7,I=8,J=9. For example: year 2015=F)